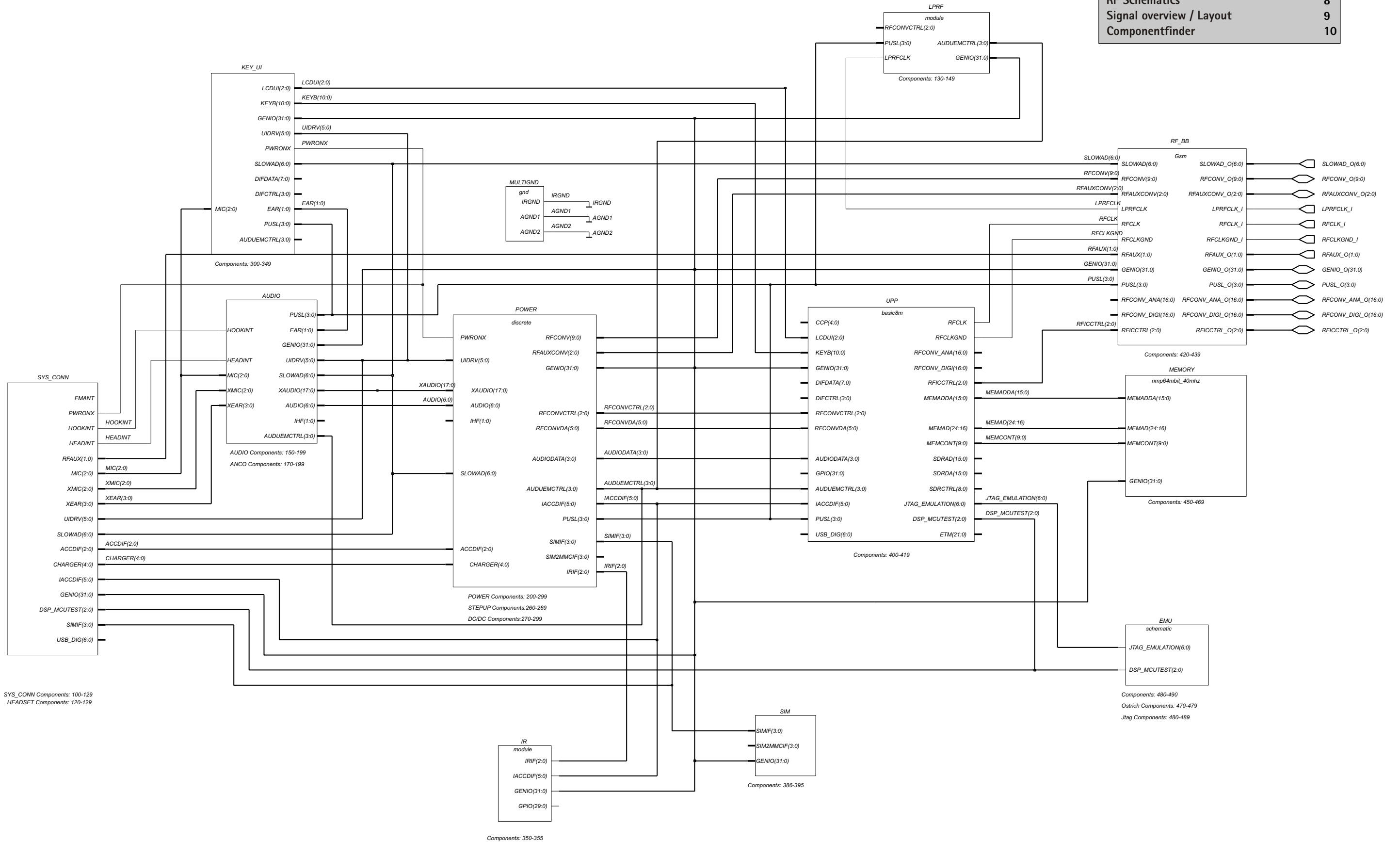
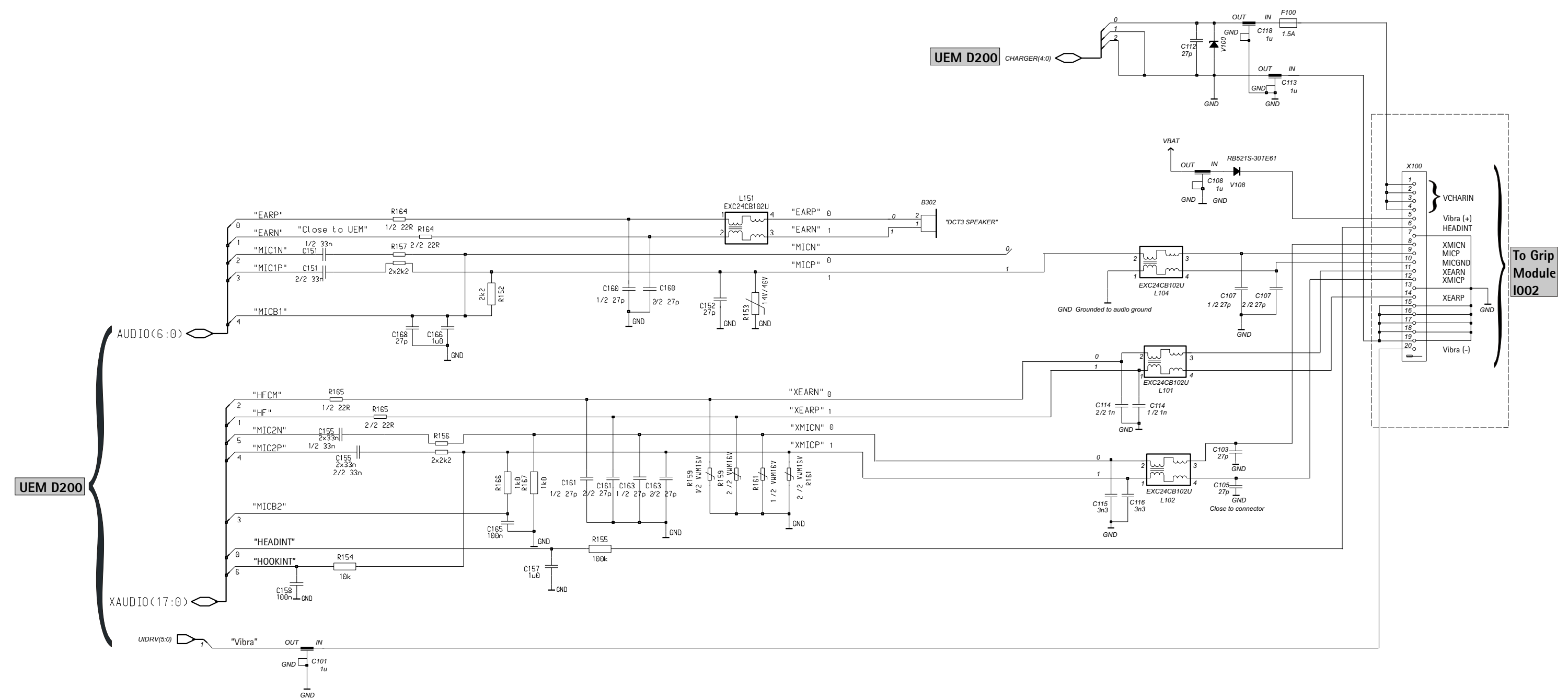
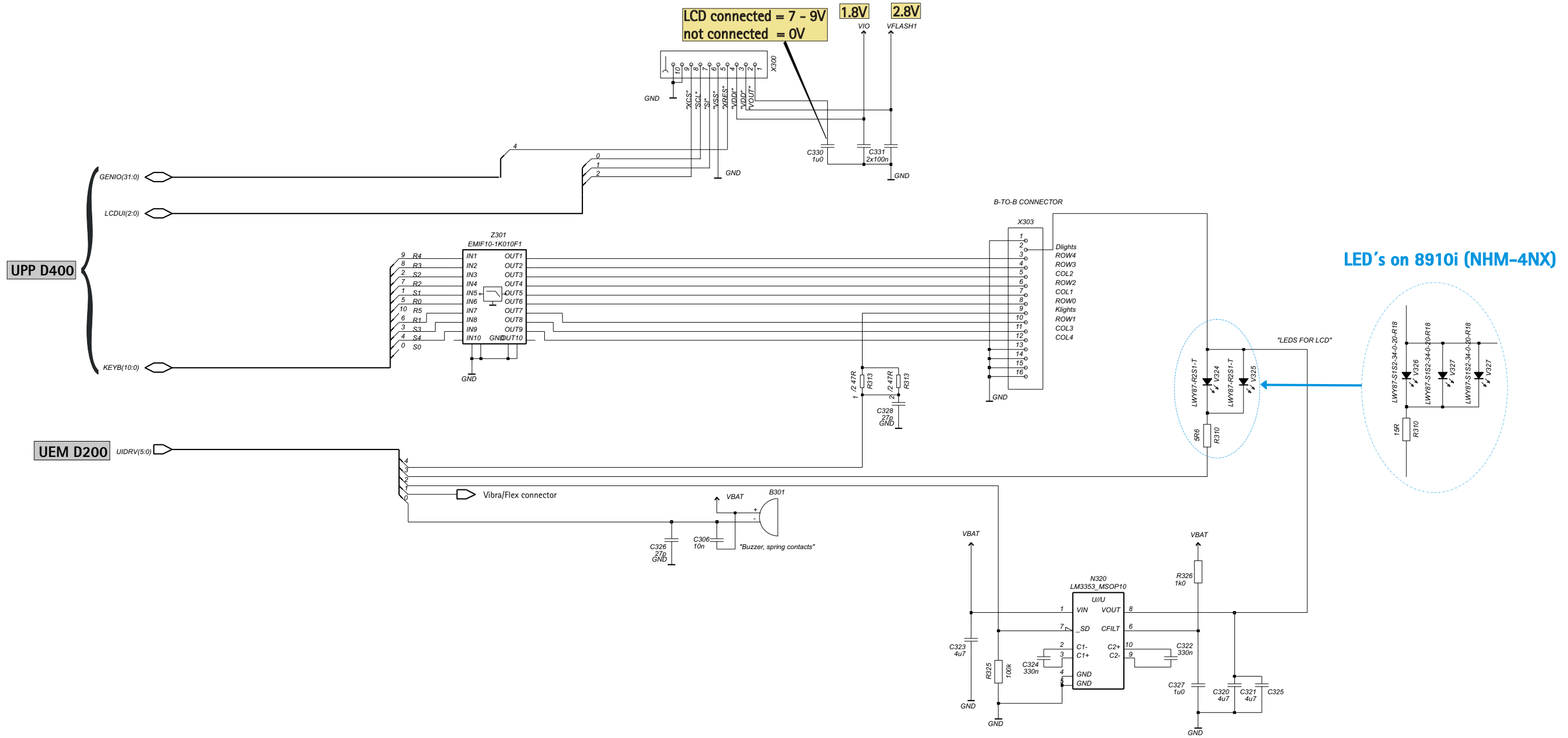

Table of Contents	Page
DCT4 Common Baseband Schematics	1
Audio / Flex connector	2
User Interface / BtoB Connector	3
UEM / Battery Connector / SimReader	4
UPP / Flash	5
Bluetooth / IRDA	6
BB - RF connection overview	7
RF Schematics	8
Signal overview / Layout	9
Componentfinder	10









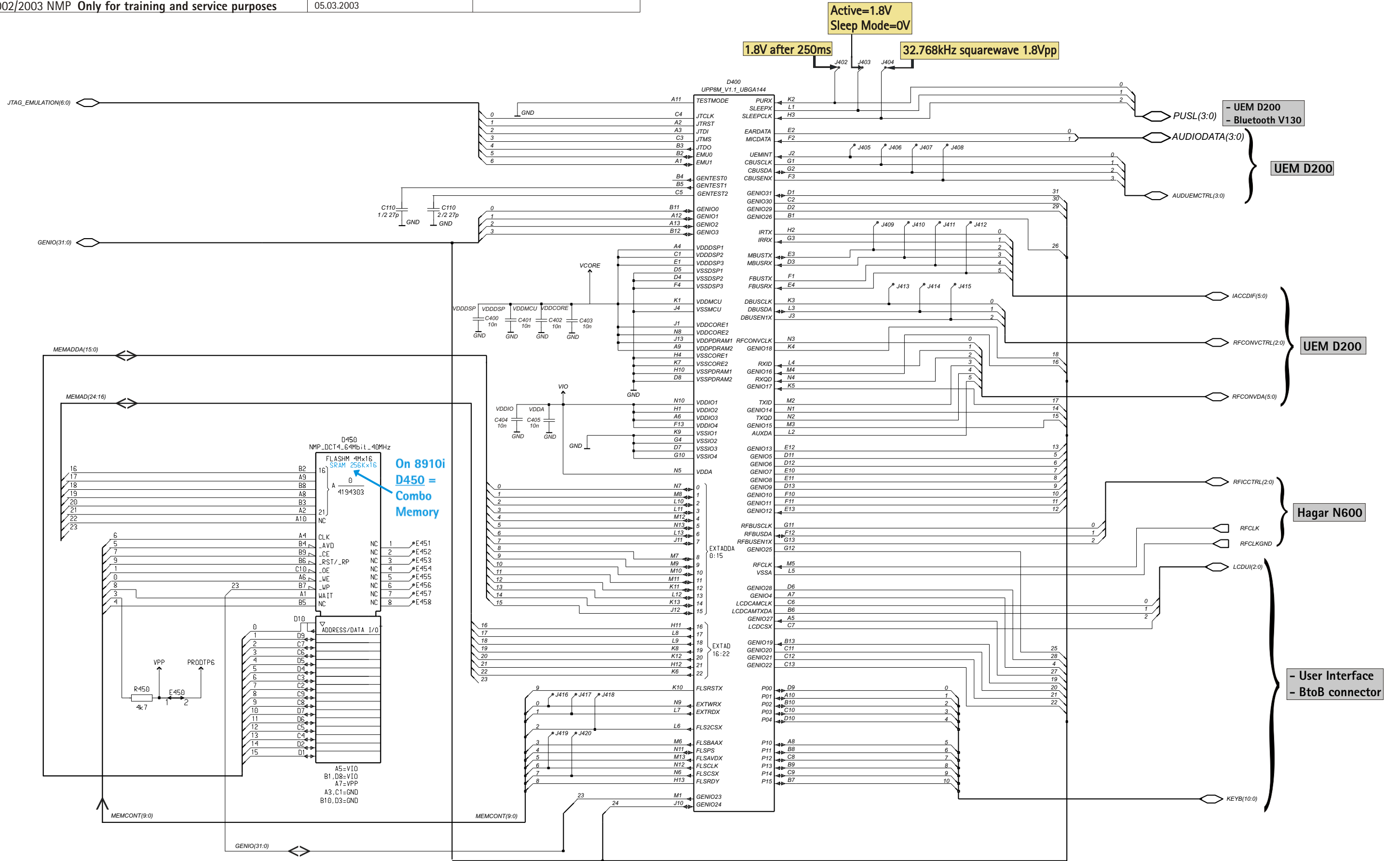

- UEM D200  
- Bluetooth V130

UEM D200

UEM D200

Hagar N600

- User Interface  
- BtoB connector

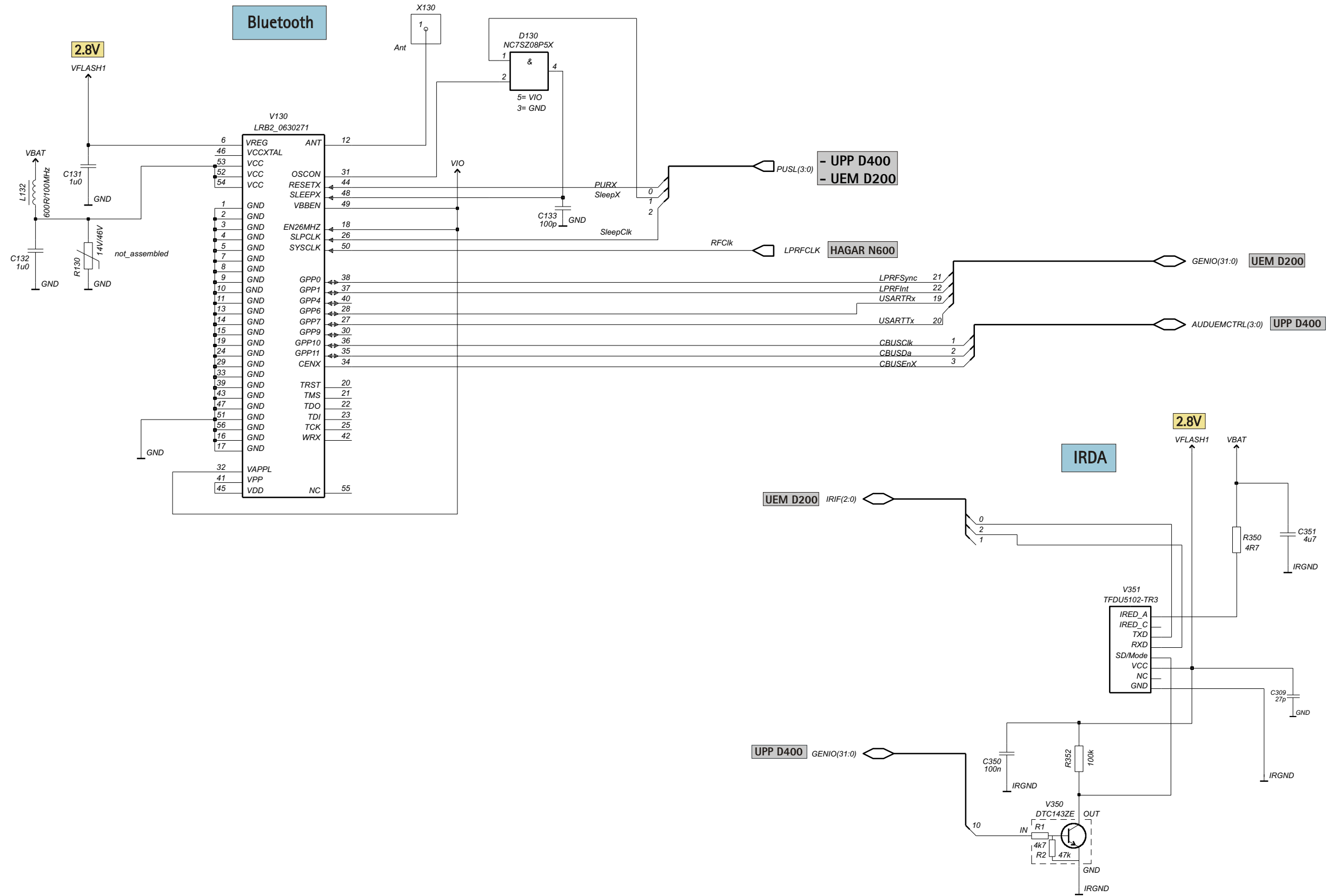

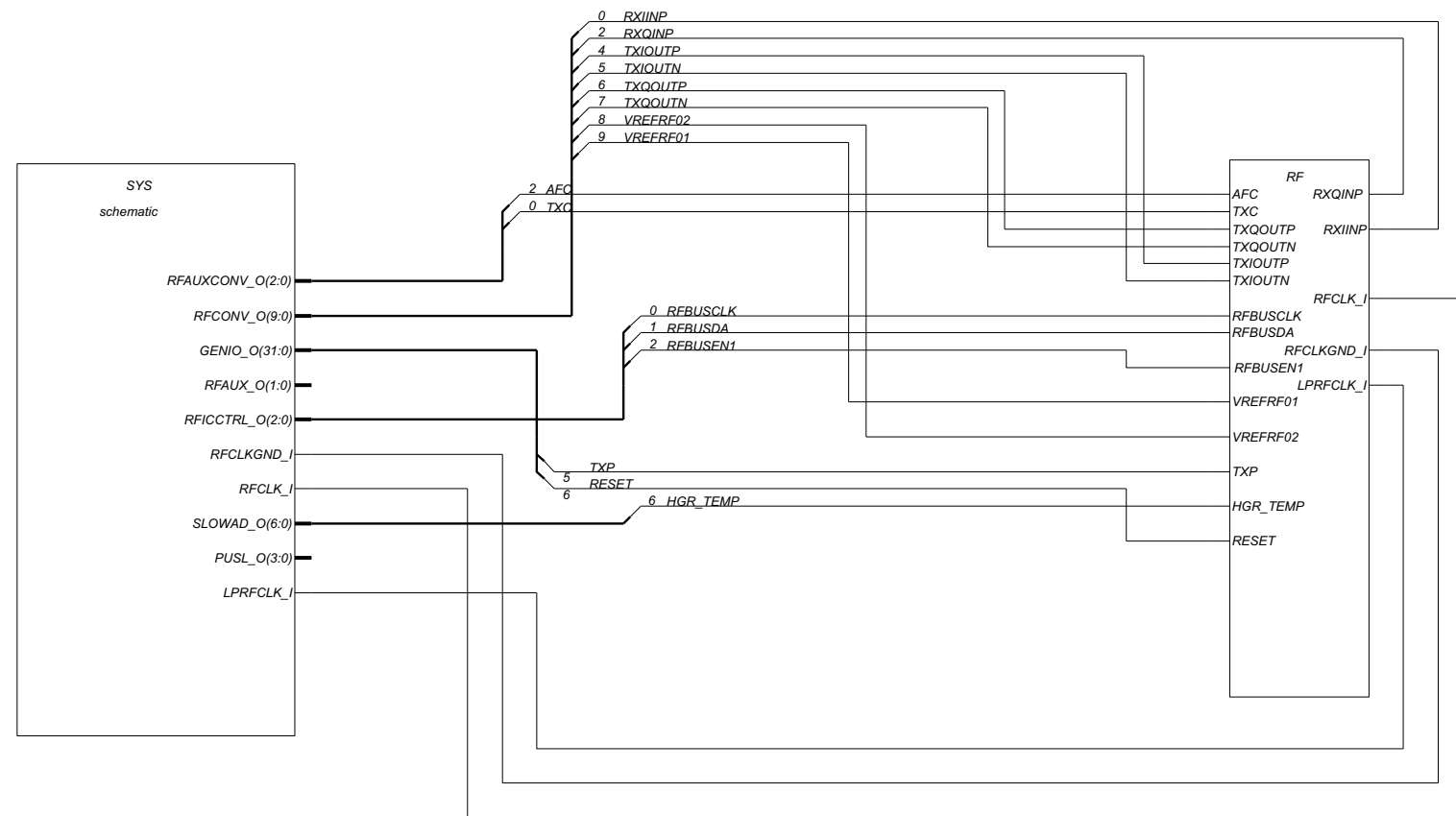

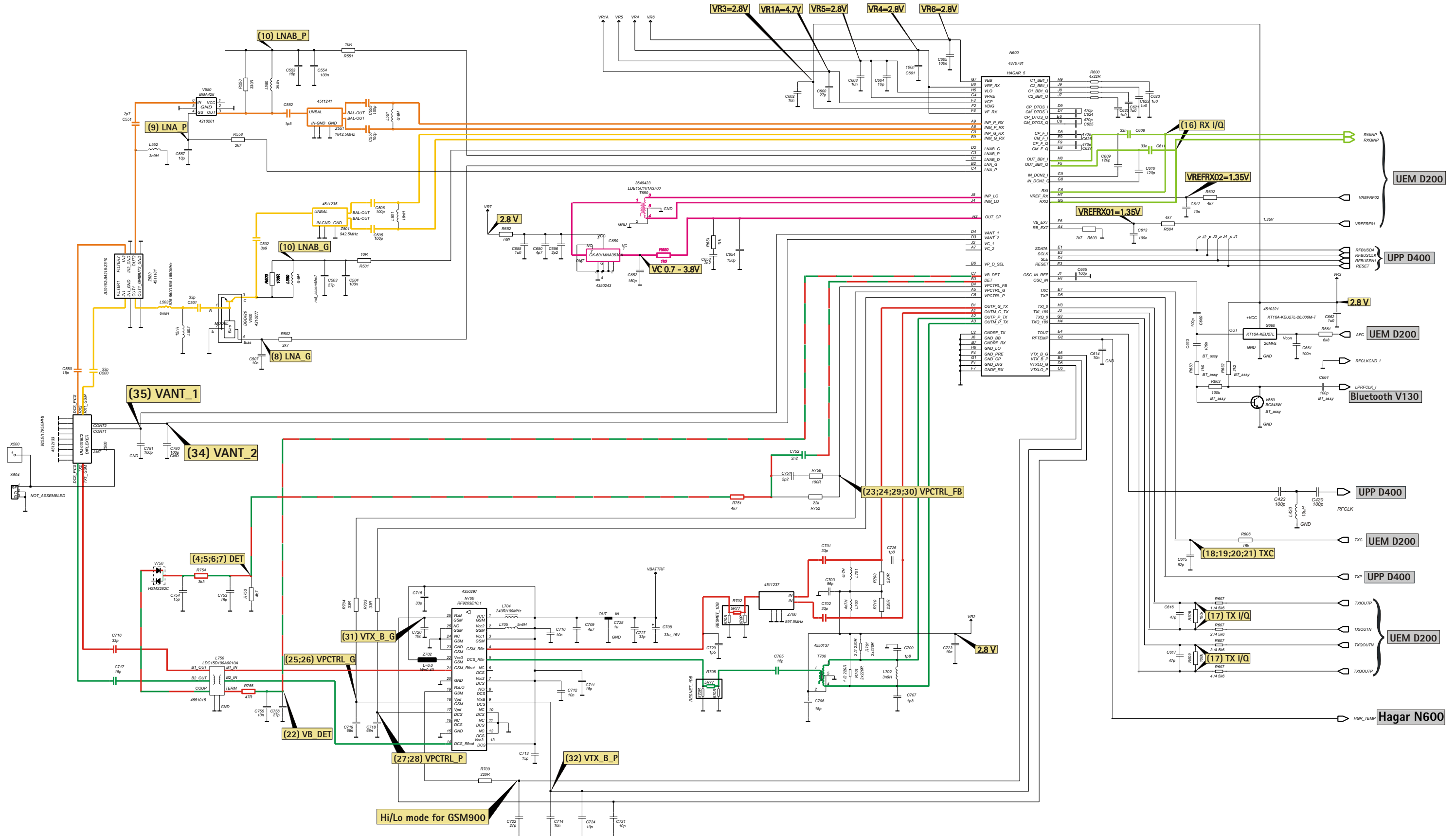



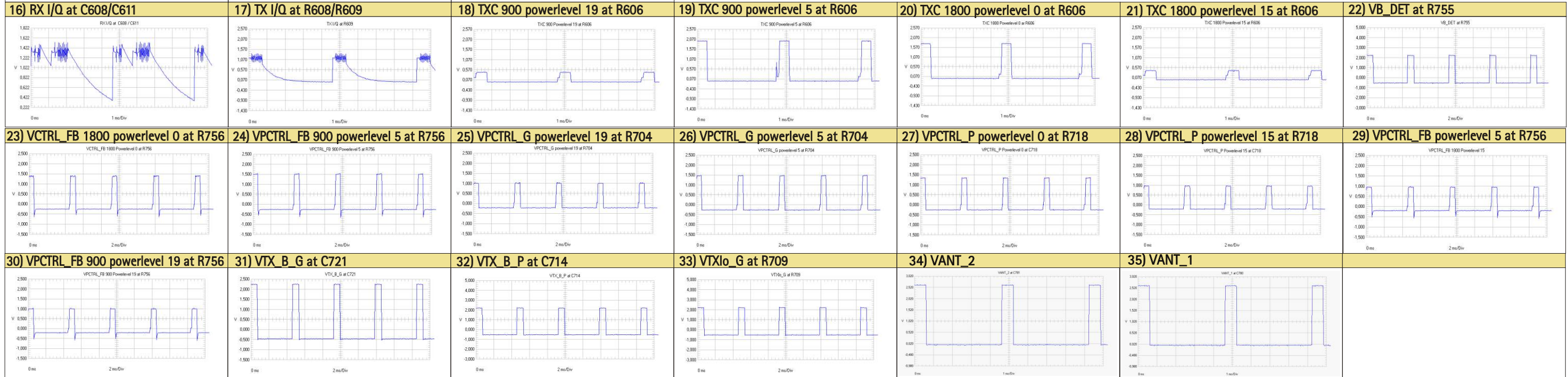
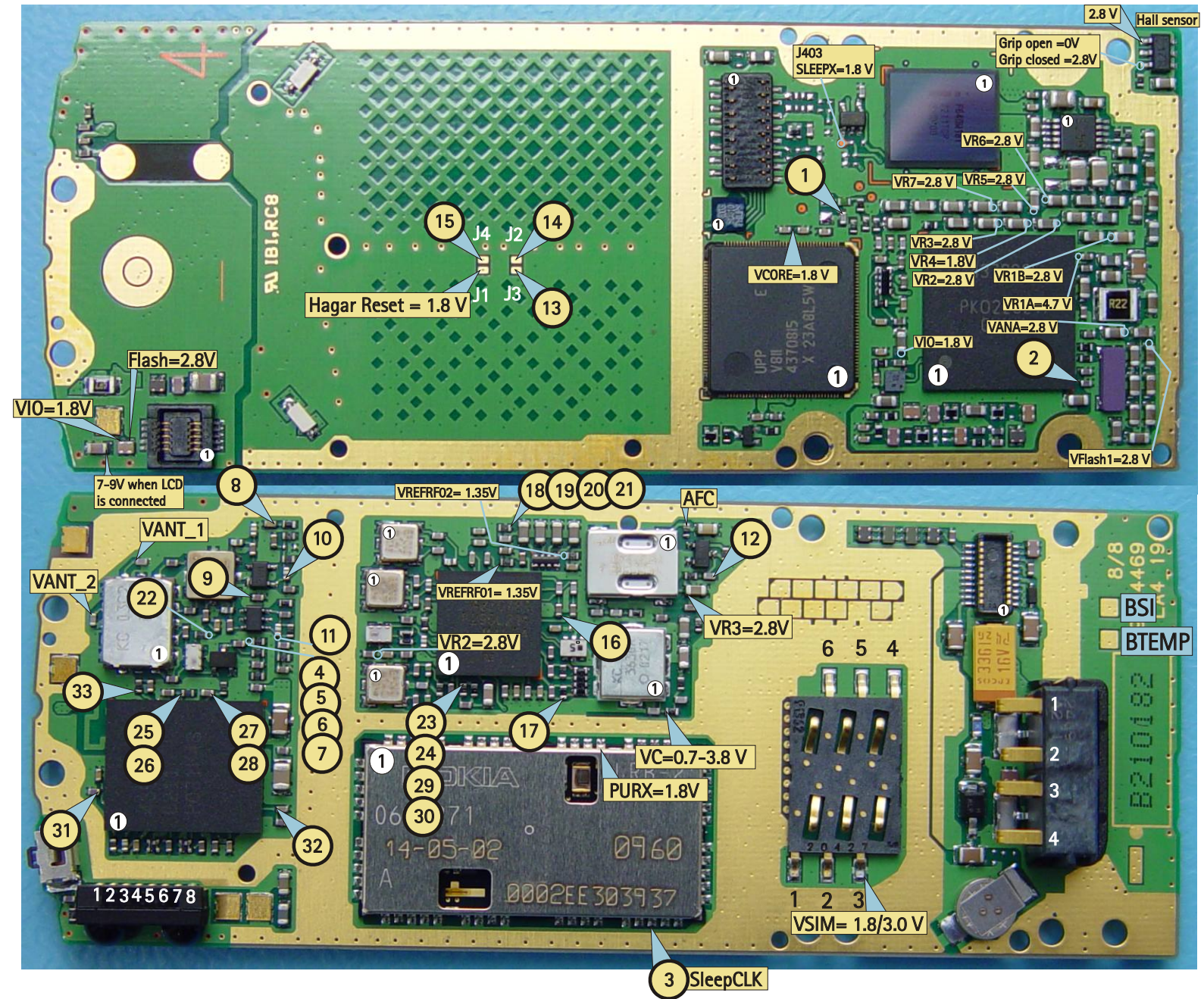
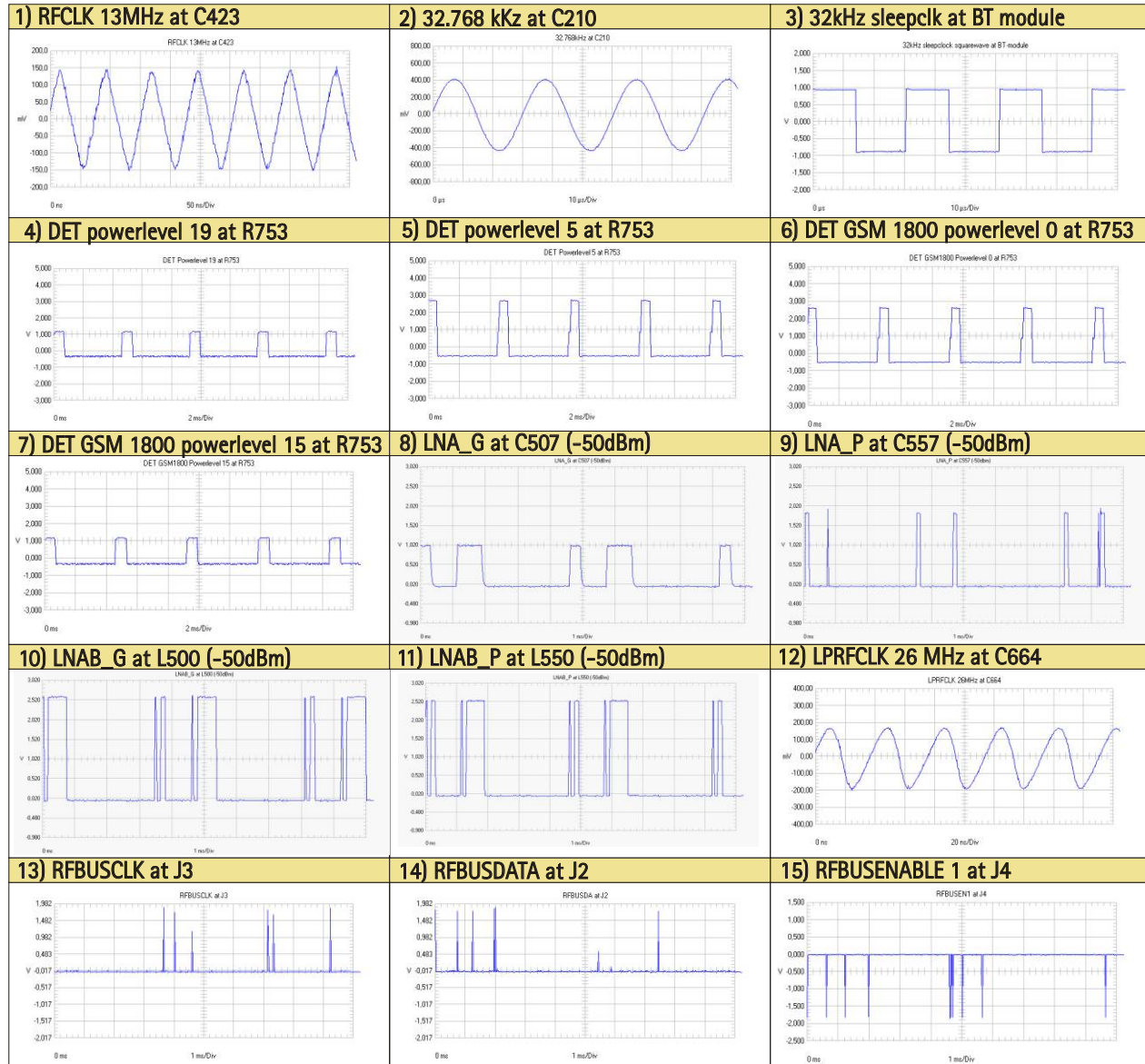

<b>B</b>	C218 - F6	C350 - A7	C616 - D3	C726 - C3	L702 - C3	R600 - D3	V750 - B3
B200 - H5	C219 - H6	C351 - B5	C617 - D3	C727 - B3	L704 - A1	R602 - D3	<b>X</b>
<b>C</b>	C220 - F5	C389 - F5	C620 - D4	C728 - B2	L705 - A1	R603 - C3	X100 - G3
C101 - G3	C221 - H6	C400 - E5	C621 - D4	C729 - B1	L750 - B3	R604 - D3	X101 - G2
C103 - G3	C222 - G6	C401 - F5	C622 - D4	C751 - C2	<b>N</b>	R606 - D4	X130 - B1
C104 - G2	C223 - G6	C402 - F6	C623 - D4	C752 - D3	N320 - H7	R607 - D3	X131 - B1
C105 - G4	C224 - G6	C403 - F6	C624 - D4	C753 - B3	N600 - D3	R608 - D3	X300 - B4
C107 - G4	C225 - H6	C404 - F6	C625 - D4	C754 - B3	N700 - B2	R609 - D3	X303 - E7
C108 - G3	C226 - G6	C405 - F6	C626 - D3	C755 - B3	<b>R</b>	R650 - E2	X386 - F2
C110 - E4	C227 - G6	C406 - F5	C627 - D3	C756 - B3	R102 - H5	R651 - E3	X500 - A4
C112 - H5	C228 - F6	C420 - D3	C650 - E3	C780 - A3	R152 - G4	R652 - E3	X501 - A3
C113 - G1	C229 - G6	C421 - F6	C652 - E2	C781 - A3	R153 - G5	R660 - E3	X505 - A5
C114 - G5	C230 - G6	C422 - F6	C653 - E3	C790 - B1	R154 - F4	R661 - E4	<b>Z</b>
C115 - F4	C231 - G6	C423 - F6	C654 - E3	<b>D</b>	R155 - H5	R662 - E3	Z301 - E6
C116 - F5	C232 - G6	C450 - G7	C655 - E3	D130 - F7	R156 - G4	R663 - E4	Z500 - A3
C118 - G2	C233 - H6	C451 - G7	C656 - E3	D200 - G5	R157 - G5	R700 - C2	Z501 - C4
C131 - B1	C234 - F6	C454 - G6	C660 - D3	D400 - F5	R159 - F4	R701 - C3	Z520 - B3
C132 - E7	C235 - H4	C500 - B3	C661 - E4	D450 - G7	R161 - G4	R702 - A1	Z551 - C3
C133 - F7	C236 - F6	C501 - B4	C662 - E3	<b>F</b>	R164 - E4	R703 - B3	Z700 - C3
C151 - G5	C237 - F6	C502 - B3	C663 - E3	F100 - G2	R165 - G5	R704 - B3	
C152 - G4	C238 - H6	C504 - B4	C664 - E3	<b>G</b>	R166 - F5	R705 - B1	
C155 - G4	C239 - F5	C505 - C4	C665 - D3	G300 - G1	R167 - F5	R709 - A3	
C157 - H5	C240 - F5	C506 - C4	C700 - C3	G650 - E3	R200 - H5	R710 - C3	
C158 - H5	C241 - F5	C507 - B4	C701 - C2	G660 - E3	R202 - F6	R751 - B3	
C160 - B5	C242 - F5	C550 - B3	C702 - C3	<b>L</b>	R206 - F5	R752 - D3	
C161 - G5	C243 - H5	C551 - B3	C703 - C3	L101 - F4	R207 - F5	R753 - B3	
C163 - F4	C260 - H6	C552 - B3	C705 - B1	L102 - G4	R301 - A1	R754 - B3	
C165 - F5	C261 - H6	C553 - B3	C706 - C3	L104 - G4	R310 - F5	R755 - B3	
C166 - G5	C262 - H6	C554 - B3	C707 - C3	L132 - E7	R311 - G1	R756 - D3	
C168 - G5	C263 - H6	C555 - C3	C708 - G3	L151 - A5	R313 - F7	<b>S</b>	
C200 - H6	C264 - H6	C556 - C3	C709 - B2	L260 - H6	R325 - H7	S300 - H7	
C201 - H5	C265 - H5	C557 - B3	C710 - A1	L261 - H6	R326 - H7	S302 - A1	
C202 - H6	C306 - A6	C600 - D3	C711 - B1	L262 - H6	R327 - H7	<b>T</b>	
C203 - F5	C309 - A7	C601 - C3	C712 - B1	L263 - H6	R350 - A5	T650 - D3	
C204 - H5	C312 - A1	C602 - D3	C713 - B2	L264 - H6	R352 - E5	T700 - C3	
C205 - H5	C319 - H7	C603 - D3	C714 - B2	L265 - H6	R388 - F5	<b>V</b>	
C206 - H5	C320 - H6	C604 - D3	C715 - A2	L420 - F6	R421 - F6	V100 - G2	
C207 - F5	C321 - H6	C605 - D3	C716 - B3	L500 - B3	R422 - G6	V108 - G3	
C208 - H6	C322 - H7	C608 - D3	C717 - B3	L501 - C3	R423 - F6	V130 - D2	
C209 - H5	C323 - H7	C609 - D3	C718 - B3	L502 - B4	R450 - F6	V324 - B5	
C210 - H5	C324 - G7	C610 - D3	C719 - B3	L503 - B4	R500 - B3	V325 - B7	
C211 - H5	C326 - A6	C611 - D3	C720 - A2	L550 - B3	R501 - B4	V350 - E5	
C212 - H5	C327 - H6	C612 - D3	C721 - A2	L551 - C3	R502 - B4	V351 - A1	
C213 - H5	C328 - F7	C613 - D4	C722 - A3	L552 - B3	R550 - B3	V500 - B3	
C214 - H5	C330 - A4	C614 - D3	C723 - C3	L700 - C3	R551 - B3	V550 - B3	
C215 - H5	C331 - A4	C615 - D4	C724 - B2	L701 - C2	R558 - B3	V660 - E4	

